

THE

**RAPID - PLY®**

**TIRE BAND BUILDER**  
**MODELS A, B, C, & D**

A COMPLETE LINE OF BELT -TYPE  
TIRE BAND BUILDING MACHINES  
48 inch THROUGH 200 inch WIDE

*Manufactured by:*

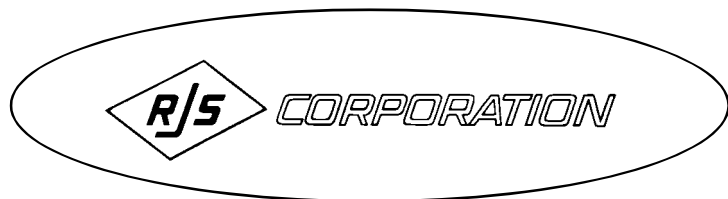

***RJS CORPORATION***  
***3400 MASSILLON ROAD***  
***AKRON, OHIO 44312***  
***USA***

***PHONE: 330-896-2387***  
***FAX: 330-896-3282***  
***sales@rjscorp.com***  
***www.rjscorp.com***

## THE RAPID-PLY BAND BUILDER

### General Description

The Rapid-Ply Band Builder is a belt-type tire band building machine which provides means for rapidly changing the tire band size over a substantial range.

The adjustment for band circumference is infinitely variable within its limits, and the size is set quickly by turning a handwheel, or in the case of the larger machines, with an optional power drive.

The universal nature of this machine makes it particularly useful in tire plants producing a wide range of tire sizes, and minimizes the capital investment required for the building of tire bands.

Each machine uses two conveyor-type flat belts, with either metal or cemented splices, depending on the machine size. These belts are used in conjunction with each other for carrying the plies, and for squeezing out the air as the band is built. These two belts are referred to as the "building belt", and "hugger belt", respectively, and their use will be more clearly understood in the following description.

### Principle of Operation

The mechanical arrangement that permits the use of standard belting and yet is infinitely variable is shown in Figure 1. The building belt passes over rolls A, C, D and E. Rollers B, D, E, and F are mounted on a carriage which slides horizontally on hardened ways.

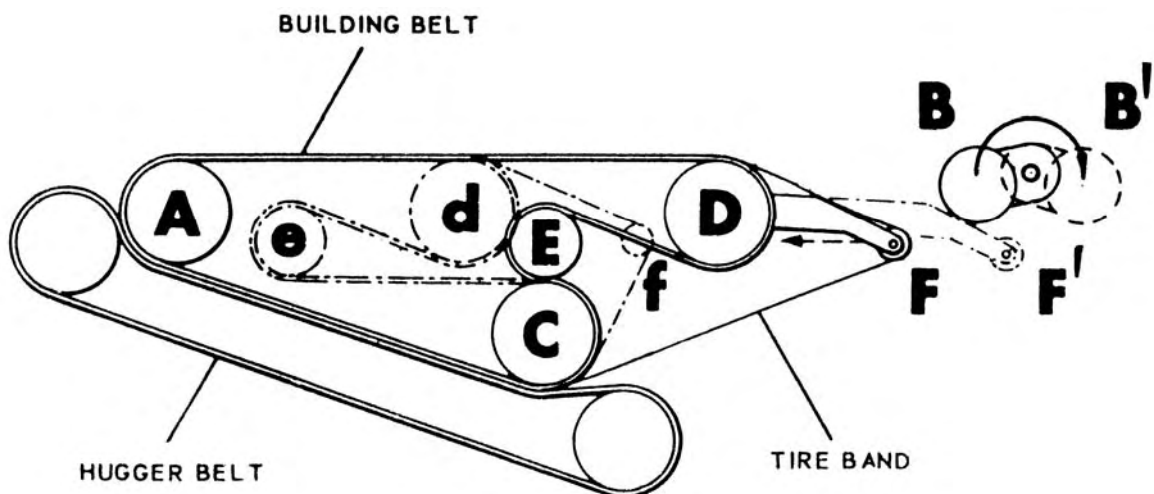

**FIG. 1**

Roller B, which is eccentrically pivoted against opposed stops, may assume a second position relative to the carriage merely by swinging it to position B'. Roller F also has a second position relative to the carriage, and the second position of roller B is to make room for roller F to move to position F'.

The tire band itself is applied over the building belt, and in addition, passes over roller F. (On the larger machines, there may be two idler rolls F, one above other.)

The tire band is not built over roller B. Roller B is merely an idler roller to assist the operator in feeding tire fabric into the machine. Since the tire band is built over roller F, the circumferential range of the machine is increased by the simple means of moving it to position F', and of course, this makes it necessary to swing roller B to position B'.

If the carriage with rollers D, E, and F is made to move to a new position marked d, e, and f, the building belt will continue to remain tight over its rollers, but the path over which the tire band is applied will have changed; in this instance, the path becomes shorter.

The machine will therefore build bands of any circumference within its range merely by positioning the carriage in the proper location. The carriage is placed in its desired position by turning a handwheel, or in the case of the larger machines, with an optional power drive.

The same principle is used in removing a completed band from the machine. For band removal, the carriage is retracted a given amount to the left, leaving the tire band loose. This retraction, however, is accomplished by an air cylinder. The building belt rolls, being in cantilever, allow the unobstructed removal of the band.

The hugger belt bears against the building belt while the tire plies are being applied, and serves to squeeze out any air, and presses the plies together. The hugger belt drops down for band removal.

On small machines the hugger belt is frictionally driven by contact with the building belt; however, on 72" wide machines, and larger, the hugger belt is usually power driven with an available accessory.

The belts on the machines are kept tracking by use of belt tracking devices, and the belts do not require V-belts integral with the flat belt for guidance purposes.

## **Available Sizes**

The Rapid-Ply machines are made in four models, designated Models A, B, C, and D. The model designation refers to a frame weight. Each model is made in several widths, and each width is available in several circumferential ranges.

The width designation is the width of the building belt, and represents the widest band which can be built on a particular machine.

The circumferential range is designated by four numbers which is best understood by giving an example, with reference to Figure 1.

If, for example, the range of a particular machine is given as 70/75-110/120, the first number, 70, designates the minimum circumference to which the machine will collapse. This does not represent the low end of the working range, since bands must be removed from the machine; however, the second number, 75, designates the low end of the working range. The third number, 110, represents the high end of the working range.

The fourth number, 120, indicates an extension of the high end of the range, which is achieved by moving the idler roll F, Figure 1, to its outward position F', thus extending the upper range, since the bands are built over roll F.

There can be minor variations in the range by making changes in the number of idler rolls F, and in their location, thus giving some degree of flexibility in the range.

In practice, the Model A is usually equipped with one idler roll F, whereas the Models B, C, and D are usually equipped with two such idlers, one above the other, but can alternately be supplied with one or none.

Because of the possible variations in equipping the machine in this regard, the following list of available machine sizes are representative in that some variation from the range listed is possible, depending upon whether or not all idlers are used.

When selecting a circumferential range, care should be taken that the low end of the range selected is not too close to the minimum band size to be built.

### AVAILABLE MACHINE SIZES

MINIMUM COLLAPSE	LOW END OF WORKING RANGE	HIGH END OF WORKING RANGE	EXTENSION OF HIGH END OF RANGE BY MOVING IDLER ROLL F, FIGURE 1 to F'
<p><b>MODEL A</b>, available in 48", 54", and 60" belt width. These widths available in the following ranges:</p>			
*45	48	65	75
57	60	84	94
63	67	95	105
70	75	110	120
<p><b>MODEL B</b>, available in 72", 96", and 124" belt width. These widths available in the following ranges:</p>			
**64	68	93	103
70	75	110	120
77	82	122	132
86	90	140	150
90	95	150	160
95	100	160	170
<p><b>MODEL C</b>, available in 132", 150", and 175" belt width. These widths available in the following ranges:</p>			
86	90	132	142
90	94	140	156
95	100	150	160
115	120	187	197
125	130	215	225
165	170	240	250
<p><b>MODEL D</b>, available in 200" belt width. This width available in the following ranges.</p>			
140	145	215	225

\*This Range Available Only in 48" and 54" Width

\*\*This Range Available Only in 72" Width

In addition to the standard widths and ranges shown, non-standard sizes will be considered, and quoted as specials.

## **Drive and Controls**

All models are furnished completely wired and piped, ready for air and electrical connections.

The Model A machine is wired for forward drive only, whereas the Models B, C, and D are provided with a reversing switch for reverse operation.

All models receive mechanical power from the motor through a clutch-brake; thus while the motor runs continuously, the clutch-brake is engaged and disengaged by actuation of the foot treadle, thereby transmitting power to the belt.

Collapse of the machine for band removal is initiated by the actuation of a foot switch. In the case of the Model A machine, an additional foot switch is provided for the actuation of a rubber-covered roller, which is standard on the machine, and is for pressing the plies tightly together.

The Models B, C, and D also have a rubber-covered roller for pressing the plies, but in this case, the hugger belt passes over this roller, and is located rearward of the main drive roll. The rubber roller on the Models B, C, and D is referred to as the wrap roll.

## **MODEL A**

The Model A may be provided with a variety of accessories. These are:

<u>Model No.</u>	<u>Description</u>
13	Single Squeegee Let-off (Self-windup type)
152	Single Squeegee Let-off (Air motor powered windup type)
107	Dual Squeegee Let-off (Air motor powered windup type)
103	Dual Fabric Servicer
103/104	Four Station Fabric Servicer (Shuttle type)
143	Guillotine Hot Knife (Available on Model 152 Let-off Only)
144	Power Drive for Band Adjustment
C-40-020	Band Blow-off Pipe

## **MODELS B, C, and D**

The following accessories may be provided on the Models B, C, and D:

1. Upper Squeegee Gum Let-off (Both air and motor traverse)
2. Rear Squeegee Gum Let-off (Both air and motor traverse)
3. Gantry-type Dual Squeegee Let-off
4. Air Motor Assist Drive for either Upper or Rear Let-off
5. Power Carriage Drive for Band Size Adjustment
6. Power Drive to the Hugger Belt, for power driving this belt when it is in either the up or down position.
7. Heavy-Duty Clutch Brake
8. Band Splice Conveyor
9. Band Blow-off Pipe to assist in band removal
10. Guillotine Hot Knife

Other accessories have been developed, as well as many minor variations in the machine too numerous to mention here. Special variations and accessories will be considered, and quoted.

## **Operation**

Band building machines of 48 inches wide through 60 inches wide usually require only one operator. Machines 72 inches wide, and wider, usually require two operators.

There are several methods of building tire bands on the Rapid-Ply machine. The selection of the method depends upon conditions external to the machine, such as the size bands to be made, floor space available, production quantity, and the availability of other equipment.

One common method is to position several Rapid-Ply machines near a bias cutter, with the operator picking up the cut plies and building bands directly on the band machine, all splices being made thereon, and the bands made to the required circumference without measuring.

A variation of this method is to have ply panels (not spliced) rolled up in a liner, again with the operator picking up cut plies as the liner is unrolled, and making all splices on the band machine directly to the desired circumference.

A second method is to position a splice conveyor behind the operator; the cut plies from the bias cutter are then spliced on the conveyor, measured to length, and fed into the band machine. In this instance, the bands are not built tightly over the machine, but are kept loose, since the band length was measured on the splice conveyor.

A similar method is also used but without measuring on the splice table; the table merely serves to feed a long pre-spliced amount of tire fabric into the machine, and the band is built to size over the machine.

These latter two methods are more commonly used when building large off-the-road tire bands, although the large bands are also successfully being built using the method of building directly to size on the machine, and making all splices thereon, without the use of a splice conveyor.

A third method employed with the Rapid-Ply machine is to feed the machine spliced tire fabric out of a roll from a servicer located behind the operator. In this case, the operator builds to the desired circumference without measuring, and makes only one splice per ply.

*Specifications subject to change without notice.*

U.S. AND FOREIGN PATENTS ISSUED



**CORPORATION**

3400 MASSILLON ROAD  
AKRON, OHIO 44312 USA

TEL: +1 330-896-2387

FAX: +1 330-896-3282

sales@rjscorp.com

www.rjscorp.com

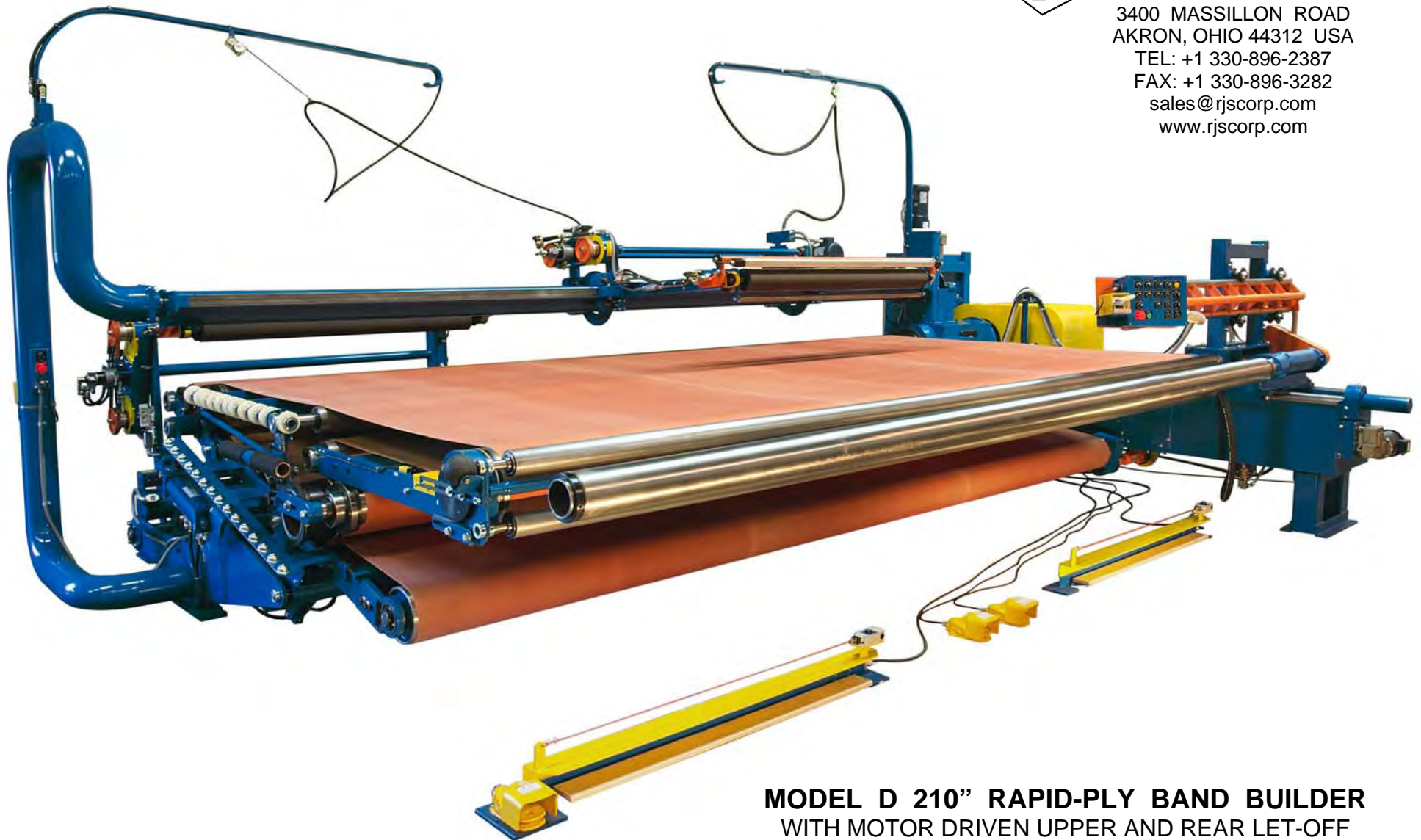

**MODEL D 210" RAPID-PLY BAND BUILDER**  
WITH MOTOR DRIVEN UPPER AND REAR LET-OFF  
AND WITH ACCESSORIES

FRONT VIEW

RJS-D210-08

**RAPID-PLY BAND BUILDER**  
 REPRESENTATIVE PHOTO  
 FOR MODELS B\*, C, & D  
 ACCESSORIES INDICATED

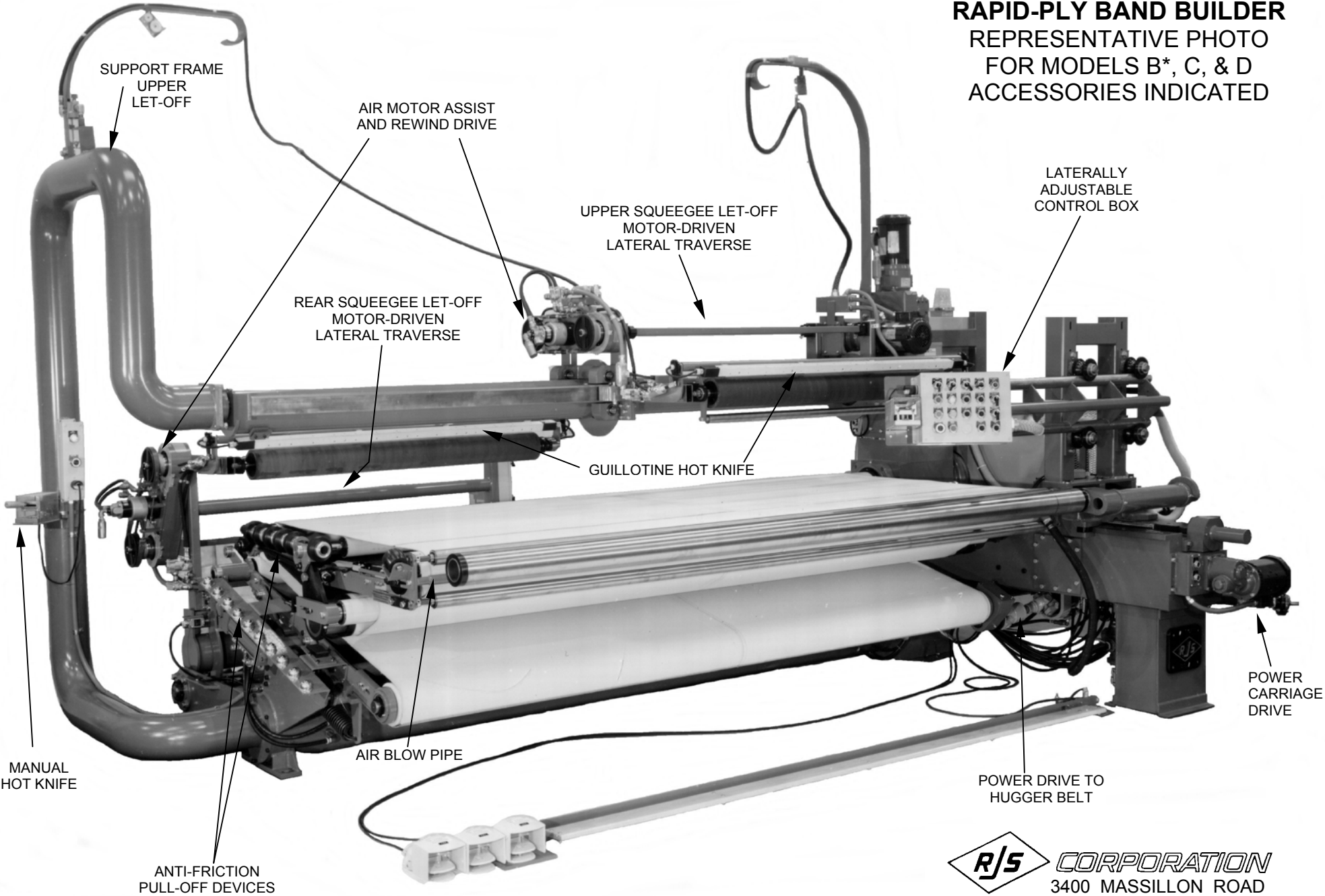

SUPPORT FRAME  
UPPER  
LET-OFF

AIR MOTOR ASSIST  
AND REWIND DRIVE

UPPER SQUEEGEE LET-OFF  
MOTOR-DRIVEN  
LATERAL TRAVERSE

LATERALLY  
ADJUSTABLE  
CONTROL BOX

REAR SQUEEGEE LET-OFF  
MOTOR-DRIVEN  
LATERAL TRAVERSE

GUILLOTINE HOT KNIFE

POWER  
CARRIAGE  
DRIVE

MANUAL  
HOT KNIFE

AIR BLOW PIPE

POWER DRIVE TO  
HUGGER BELT

ANTI-FRICTION  
PULL-OFF DEVICES

**R/S** CORPORATION  
 3400 MASSILLON ROAD  
 AKRON, OHIO 44312  
 U.S.A.

\*DOES NOT APPLY TO MODEL B. 72\*