

**THERE'S TENSION
IN THIS FAMILY!**

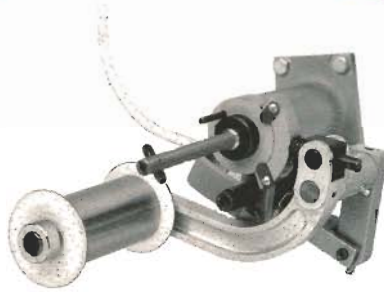

MODEL SS-5



MODEL SS-10A



MODEL SS-10B



MODELS
SS-14A
SS-14B



MODEL SS-18

THE **R/S** FAMILY OF

**SPECIAL
SERIES**

TENSION CONTROLLERS

FOR THE WIRE & FILAMENT INDUSTRY



BULLETIN NO. SS-793

3400 MASSILLON RD. • AKRON, OHIO 44312 U.S.A. • PHONE 216-896-2387 • TOLL FREE 800-637-5700 • TELEX 986312 • FAX 216-896-3282

THE SS* FAMILY

The family of **Special Series** Tension Controllers provides a selection of a variety of mechanical tensioning devices used for the pull-out of wire or filaments from the user's spool at uniform tension, with automatic braking when the pull-out slacks or stops.

This standardized series of controllers is arranged and identified according to the flange diameter of the spool, ranging from 5" (127mm) to 18" (457mm) diameter.

SELECTING A CONTROLLER

While the basic dimensions of each controller in the series are maintained, options of right or left hand, spindle angle (chosen from the dimension chart), and controller orientation are selected. In addition, the spindle diameter, length, and spool engagement device, such as a drive pin, may be customized to accommodate each application. Spindle adaptors may be supplied to fit spools of large bore.

*SPECIAL SERIES

CONTROLLER MOUNTING ORIENTATION

The controller hand is defined by which side of the spindle the control arm and roller are positioned. When viewing the end of the spindle, the unit is right hand if the arm and roller are to the right, and left hand if the arm and roller are to the left of the spindle. This rule applies to all orientations of controllers.

In addition to hand, the controllers are specified by the user according to whether the control arm and roller are to be in either the up or down position relative to the spindle, and whether the pull-out of wire is to be horizontal or vertical.

If the pull-out of wire from the controller is in the vertical direction, the unit is referred to as "vertical take-off"; whereas, if the pull-out is horizontal, the unit is referred to as "horizontal take-off".

There are eight possible controller mounting orientations, and to simplify selection, these are illustrated on page 5.

The controllers are manufactured in accordance with the customer's specific selections of spindle angle, controller either right-hand or left-hand, con-

The following are the description, operating characteristic and picture of each family member for their most commonly used

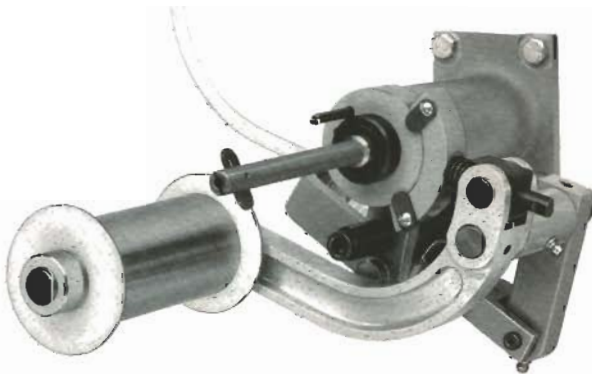

MODEL SS-5

Max. spool flange diameter, 5" (127 mm)
 Min. spool core diameter, 1 1/2" (38 mm)
 Tension range 0.5 to 3 lb. (0.23 to 1.4 kg)
 Maximum spool weight 30 lb. (13.6 kg)
 Main spindle mounted on ball bearings

Tension/pressure data shown for controller orientation roller down, vertical take-off of wire. When supplied for horizontal take-off of wire, the minimum wire tension is 0.5 lb. (0.23 kg).

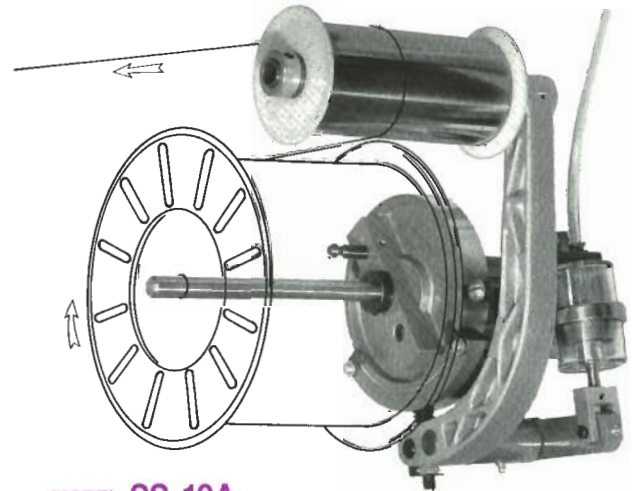
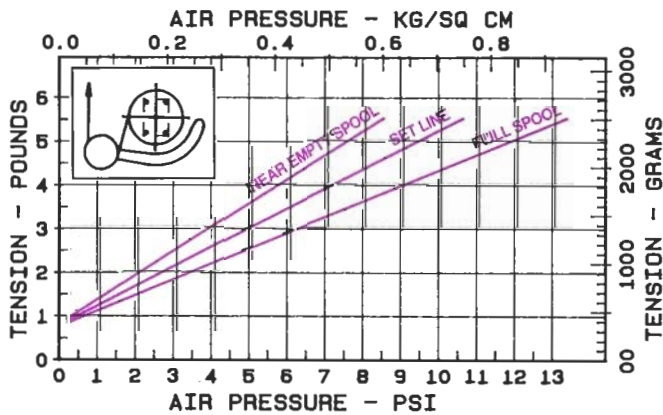

MODEL SS-10A

Max. spool flange diameter, 10" (254 mm)
 Min. spool core diameter, 4" (102 mm)
 Tension range 1 to 5 lb. (0.45 to 2.3 kg)
 Maximum spool weight 95 lb. (43 kg)
 Main spindle mounted on ball bearings

Tension/pressure data shown for controller orientation roller up, horizontal take-off wire.

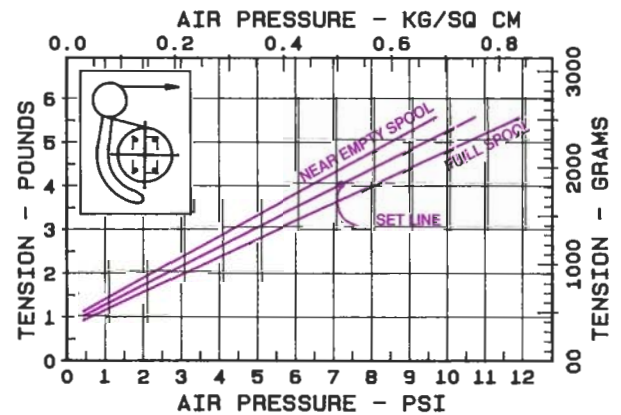

trol arm and roller either up or down, and wire take-off either horizontal or vertical.

OPERATING PRINCIPLE

All controllers in the **SS** family employ air pressure acting upon a rolling-diaphragm air cylinder which delivers a load to the brake arm. Operating on the principle of force-balance, each controller of the same type receiving the same air pressure, and the same amount of wire on their spools, will deliver the same tension.

The wire tension comes about through the use of a brake drum and shoe and is regulated by a control arm with an idler roller over which the wire passes as it is pulled from the spool.

When in operation, a state of balance between the loading of the control arm and the friction of the shoe on the brake drum results in a constant tension. The wire tension from this force-balance system is, within limits, independent of the coefficient of friction between the brake shoe and drum.

The tension is changed by merely adjusting the air pressure by precision regulator to produce the desired wire tension. Except for the brief period when tension is being changed, there is no air flow and no compressed air is consumed. Furthermore, the rolling diaphragm air cylinder is completely sealed, and has zero air leakage. A multitude of controllers may be ganged to the same air pressure system. If their spools contain the same amount of wire, the pull-out tension of each controller is the same.

In cases where pressurized air is not available, the controllers may be actuated by gravity loading in lieu of the air pressure, but the adjustability and tension range may be limited.

CONSTRUCTION

The **SS** family of controllers is simple but precise in design. The brake drum is turned and finish-ground to a close tolerance and smooth finish.

The brake shoe is bonded to its back-up plate and is machined to a decimal size to result in a precise fit to the brake drum.

ed orientation:



MODEL SS-10B

Max. spool flange diameter, 10" (254 mm)
 Min. spool core diameter, 3" (76 mm)
 Tension range 0.5 to 5 lb. (0.23 to 2.3 kg)
 Maximum spool weight 95 lb. (43 kg)
 Main spindle mounted on ball bearings

Tension/pressure data shown for controller orientation roller down, horizontal take-off wire. Automatic braking of controller upon slowing or stopping wire pull-out is approximately 75% of Model SS-10A.

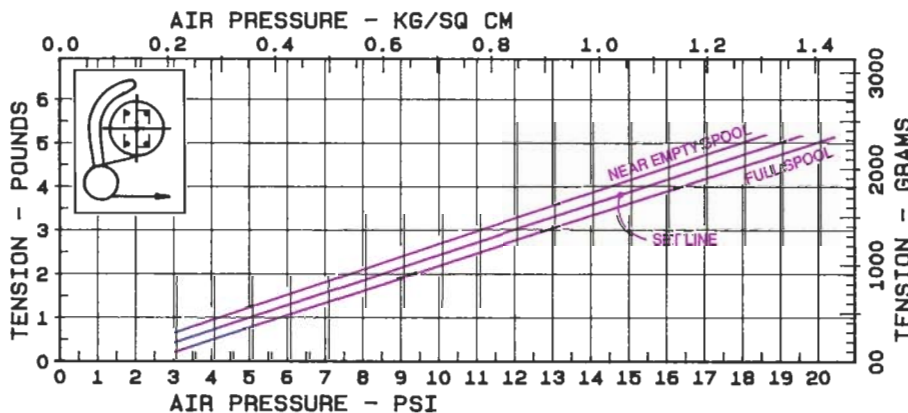

MODEL SS-14A

Max. spool flange diameter, 14" (356 mm)
 Min. spool core diameter, 4" (102 mm)
 Tension range 1 to 5 lb. (0.45 to 2.3 kg)
 Maximum spool weight 95 lb. (43 kg)
 Main spindle mounted on ball bearings



MODEL SS-14B

Max. spool flange diameter, 14" (356 mm)
 Min. spool core diameter, 4" (102 mm)
 Tension range 1 to 5 lb. (0.45 to 2.3 kg)
 Maximum spool weight 200 lb. (91 kg)
 Main spindle mounted on tapered roller bearings

Tension/pressure data shown for both Models SS-14A and SS-14B orientation roller up, horizontal take-off of wire.

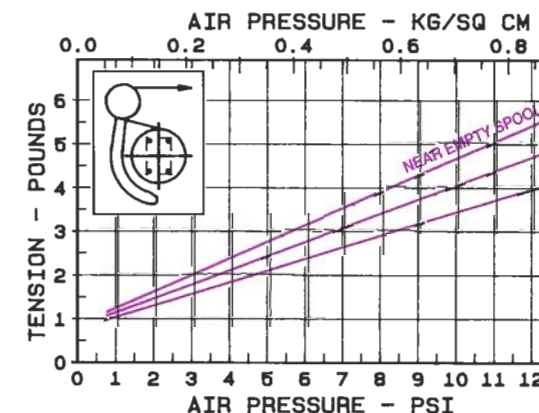

Anti-friction bearings are employed in the spindle, control arm roller and arm pivot, and in the brake arm receiving load from the air cylinder.

OPTIONS

In addition to the selection of controller mounting orientation, spindle angle, spindle length and diameter, and spindle adaptor, some models may be provided with a limit switch to indicate the control arm roller has moved back indicating that the spool is empty.

Other options include spool latches of various kinds to positively retain the spool on the spindle, and in some models, magnet spool drives may be provided.

Complete custom systems may also be provided by **RJS**, including mounting frames, air pressure control systems (both manual and servo controlled), and wire guiding and organizing devices employing either rollers or eyelets.

OPERATING CHARACTERISTICS (WIRE TENSION VS. OPERATING PRESSURE)

The operating characteristics depend upon the mounting orientation of the controller, that is, whether the control arm roller is up or down or configured for horizontal or vertical take-off wire.

The **SS** controllers usually are operated at a maximum pull-out tension of 5 lb. (2.3 kg) but some controller models may be modified to operate at tensions higher than standard. The typical operating speed of the controllers is a few feet or meters per minute to 325 feet (100 meters) per minute, but many applications of 1000 feet (300 meters) per minute or more have been filled. The heat generated at the brake drum/brake shoe is always a consideration in applications involving high tension and/or high speed. For guidance in such cases, contact the **RJS** engineering department.

Braking occurs automatically when pull-out slacks or stops. The amount of braking depends upon the mounting orientation, and will vary according to the size and mass of the spool, and the operating applied air pressure.



4A, SS-14B. Controller



MODEL SS-18

Max. spool flange diameter, 18" (457 mm)
 Min. spool core diameter, 5 1/4" (133 mm)
 Tension range 1 to 5 lb. (0.45 to 2.3 kg)
 Maximum spool weight 450 lb. (205 kg)
 Main spindle mounted on tapered roller bearings

Tension/pressure data shown for controller orientation roller up, horizontal take-off wire.

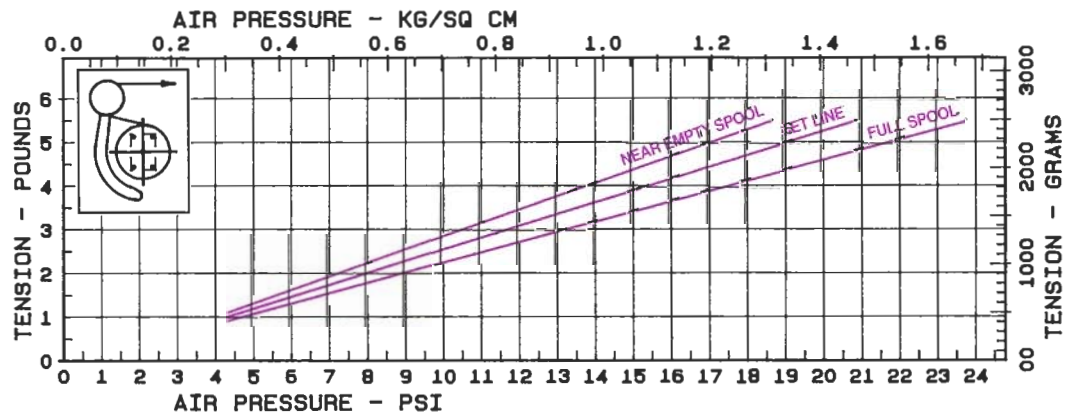
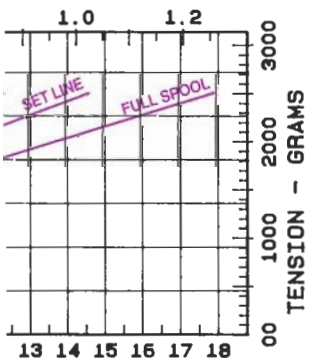

AVAILABLE CONFIGURATIONS

FOR CONTROLLERS

Configuration must be specified at time of order.

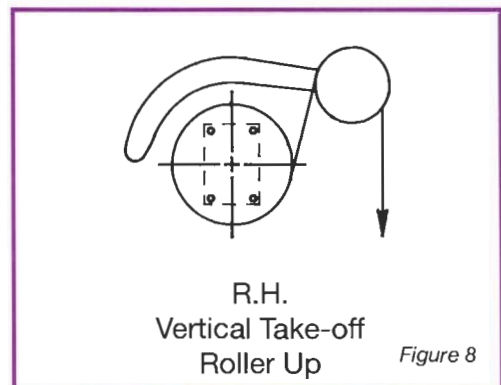
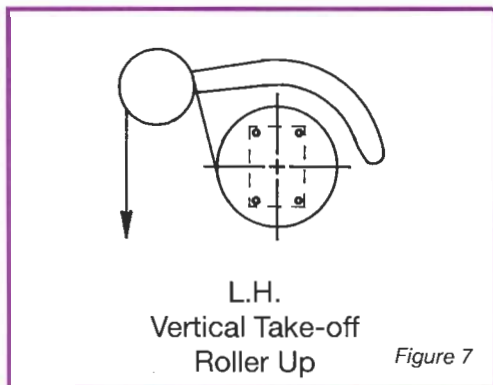
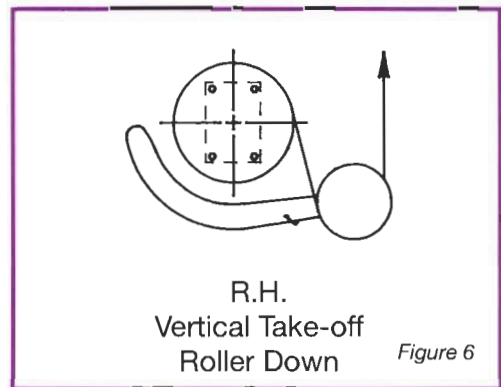
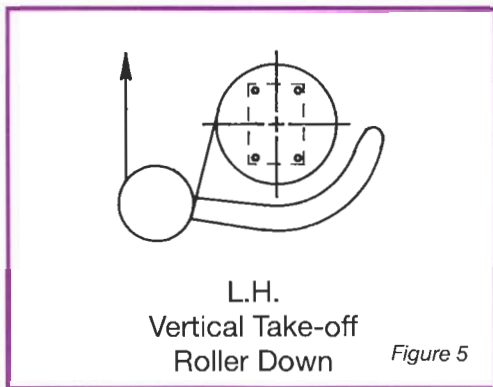
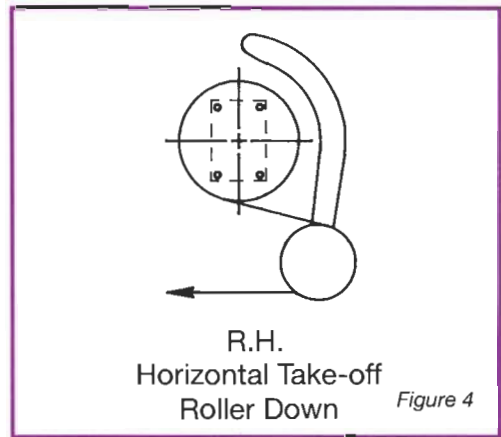
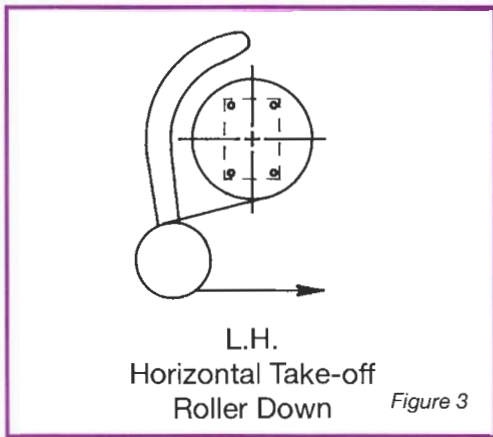
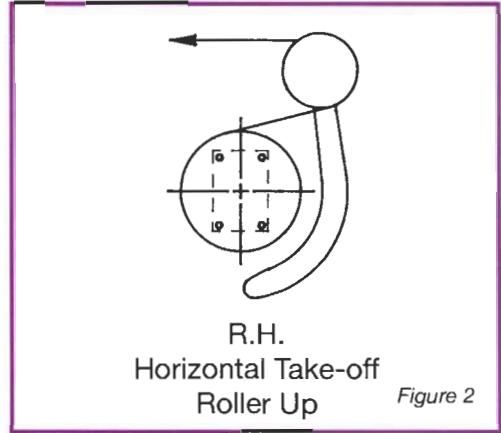
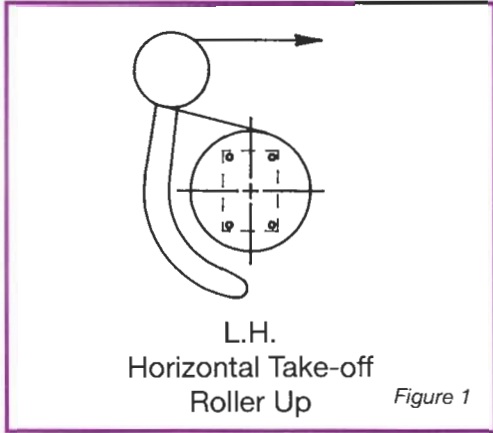

DIMENSIONAL INFORMATION
FOR THE FAMILY OF *RJS* SPECIAL SERIES
TENSION CONTROLLERS

Appearance varies according to model and mounting orientation.

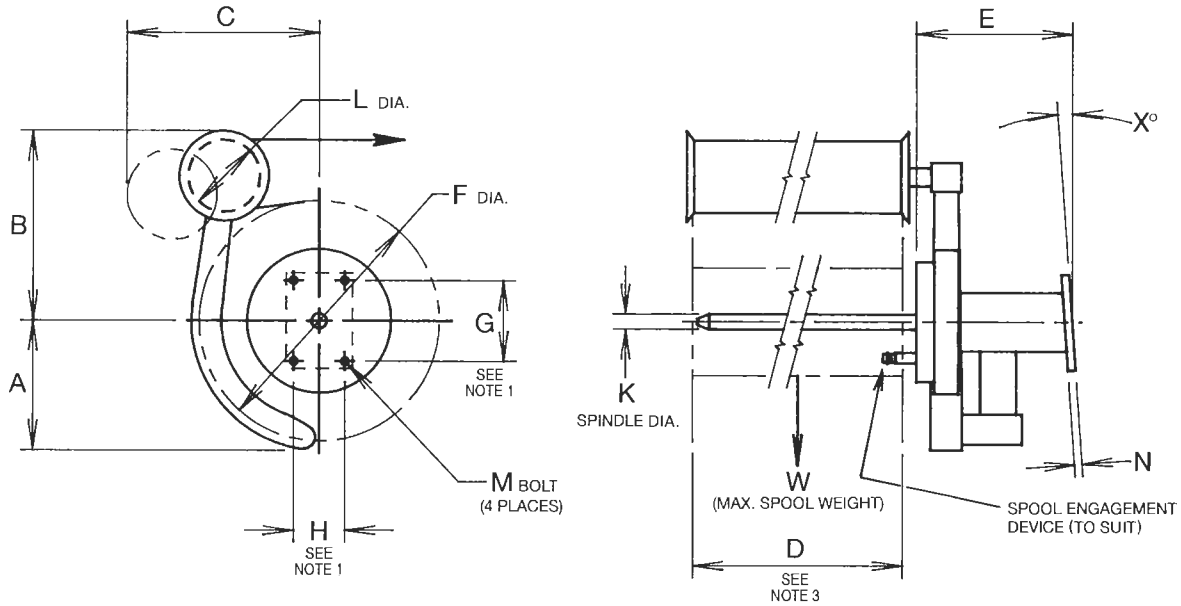

INCHES
MM

CONTROLLER MODEL*	A	B	C	D SEE NOTE 3	E	F MAX. DIA.	G SEE NOTE 1	H SEE NOTE 1	K DIA. TYPICAL	L DIA.	M BOLT	N	W MAX. LOAD	X° SPINDLE ANGLE
SS-5	4	4 ³ / ₄	5 ¹ / ₄	4	5 ⁷ / ₁₆	5	2 ⁷ / ₈	2 ¹ / ₈	5 ⁵ / ₈	2	5 ⁵ / ₁₆	5 ⁵ / ₁₆	30 LB	0° 4° 9°
	102	121	133	102	138	127	73.0	54.0	15.9	51	M8	8	14 KG	
SS-10A	6	7 ⁷ / ₈	8	13	6 ¹ / ₂	10	3 ³ / ₈	2 ¹ / ₈	3 ³ / ₄	3	5 ⁵ / ₁₆	5 ⁵ / ₁₆	95 LB	0° 4° 9°
	152	200	203	330	165	254	85.7	54.0	19.1	76	M8	8	43 KG	
SS-10B	5 ¹ / ₄	7 ⁷ / ₈	8 ¹ / ₂	13	6 ¹ / ₂	10	3 ³ / ₈	2 ¹ / ₈	3 ³ / ₄	3	5 ⁵ / ₁₆	5 ⁵ / ₁₆	95 LB	0° 6° 9°
	133	200	216	330	165	254	85.7	54.0	19.1	76	M8	8	43 KG	
SS-14A	6	10 ¹ / ₈	12 ¹ / ₂	13	6 ¹ / ₂	14	3 ³ / ₈	2 ¹ / ₈	3 ³ / ₄	3	5 ⁵ / ₁₆	5 ⁵ / ₁₆	95 LB	0° 4° 9°
	152	257	318	330	165	356	85.7	54.0	19.1	76	M8	8	43 KG	
SS-14B	6	10 ¹ / ₈	12 ¹ / ₂	13	7 ¹ / ₂	14	3 ³ / ₄	2 ¹ / ₂	1	3	3 ³ / ₈	7 ⁷ / ₁₆	200 LB	0° 4° 9°
	152	257	318	330	191	356	95.3	63.5	25.4	76	M10	11	91 KG	
SS-18	6 ¹ / ₈	15 ³ / ₈	9 ¹ / ₄	13 ¹ / ₄	8 ⁹ / ₁₆	18	4 ¹ / ₄	3 ¹ / ₄	1 ³ / ₄	4	7 ⁷ / ₁₆	7 ⁷ / ₁₆	450 LB	0° 4°
	156	391	235	337	217	381	108.0	82.6	44.5	102	M12	11	204 KG	

NOTE 1: The mounting pattern is always supplied with G dimension vertical and H dimension horizontal regardless of the direction of wire take-off.

NOTE 2: Dimensions may vary to a specific application.

NOTE 3: Spool width is representative and is specified by customer.

*The numeral in the controller model indicates the maximum spool flange diameter in inches.



RJS CORPORATION

RJS CORPORATION
 3400 MASSILLON RD., AKRON, OH 44312 U.S.A.
 TELEPHONE: 216-896-2387
 TOLL FREE: 800-637-5700
 TELEX: 986312 FAX: 216-896-3282